

T - Branch Closure



1. Description

It is designed by modular method to change the length of closure and branch direction. It is possible to assemble or dis-assemble the closure without any special tools. The maintenance of T-branch closure can be done without cutting the ducts, and can be completed only by reopening upper modular part. T-branch closure is designed to connect two microduct bundles and to branch-off tubes without any interruption of connectivity.

2. Benefit

- Light weight
- Easy installation
- Easy branching
- Microduct protection at joint/distribution point
- Can accommodate various types of microduct

3. Technical Specifications

Item	Product Code	W(mm)	D(mm)	H(mm)	Weight(g)	Thickness (mm)	material	Port No.
T Branch Closure	RUT4K	310	195	80	656	3	PP	3

4. Application duct

- Below DB 5/3.5mm 24way (OD:36.4mm)
- Below TWD 7/3.5mm 12way (OD:30.0mm)

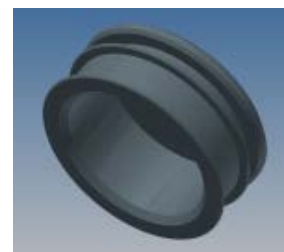

5. Design Overview

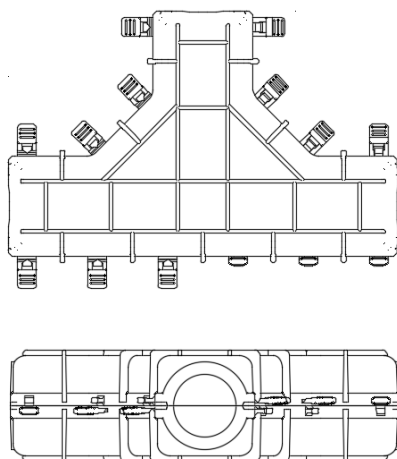

6. Rubber Sealing Cap

Rubber sealing cap consists of Main port and Distribution port, and the Microduct, according to its different type and configuration, can be applied to different Rubber Sealing Cap

Main / Distribution Port

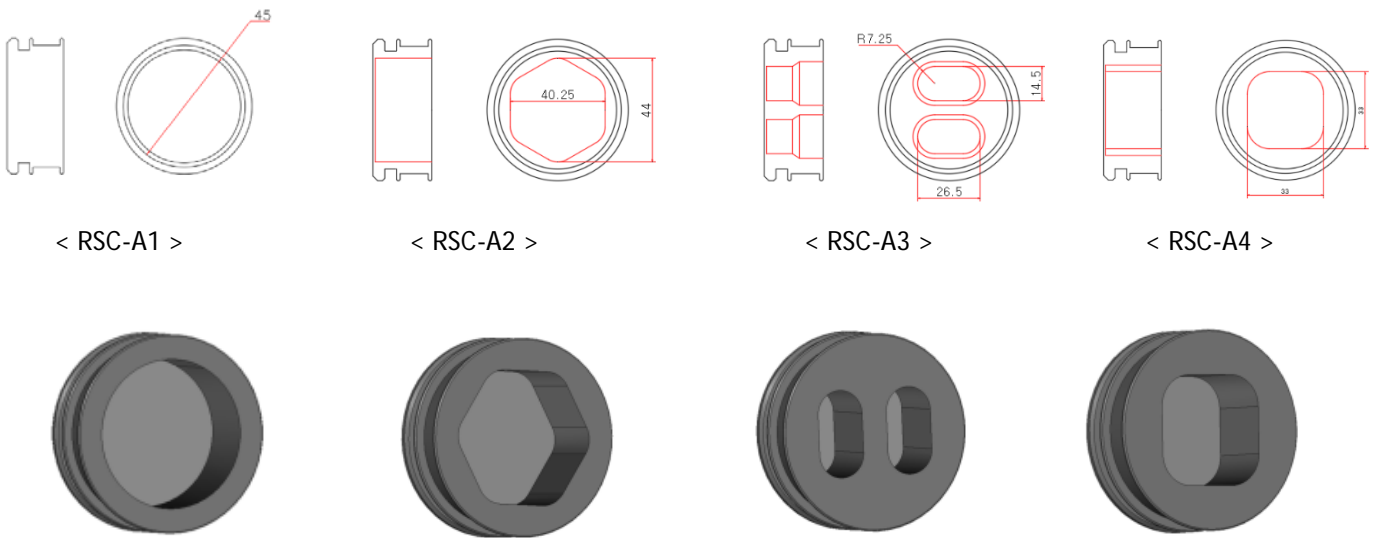

Rubber Sealing Cap Specifications

Item	Product Code	Dimension (mm)	Application Port	Hole size (mm)	Weight (g)
Rubber Sealing Cap	RSC-A1	Ø60 x 25	Main / Distribution	Ø45	26
Rubber Sealing Cap	RSC-A2	Ø60 x 25	Main / Distribution	40.25 x 44	33
Rubber Sealing Cap	RSC-A3	Ø60 x 25	Main / Distribution	14.5 x 26.5 x 2holes	51
Rubber Sealing Cap	RSC-A3	Ø60 x 25	Main / Distribution	33 x 33	41

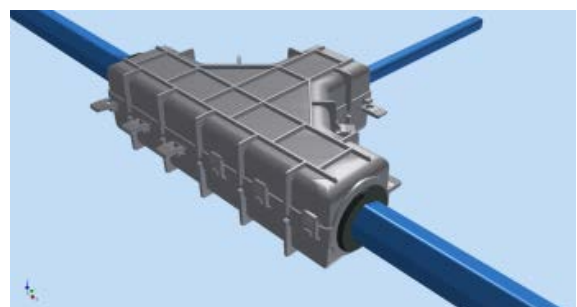
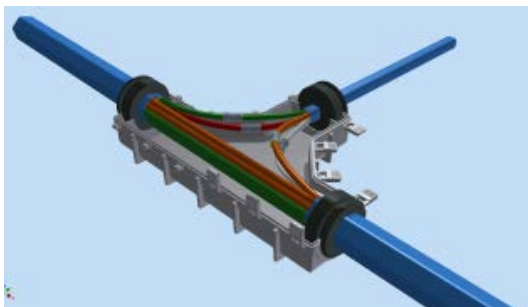

7. T - Branch Closure User Manual



Prepare T branch closure, tools, connectors, etc.



Cut the sheath by round cutter



Remove the sheath by using splitter.



Make a hole of rubber sealing cap to fix the microduct.



Insert microduct inside rubber cap and fix with cable ties.

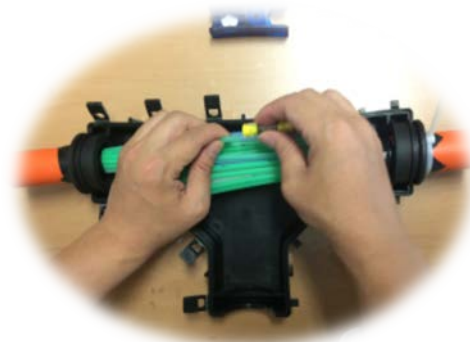

Align and cut microtubes from both sides.



Connect microtubes outside of closure.



Connect microtubes starting from inside to outside ones.



Connect microtubes starting from inside to outside ones. (2)

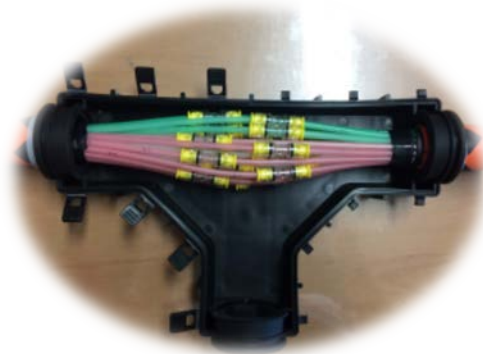

After microtubes connection, sort tubes in zip zap shape.



Assemble the cover and connect the hooks.



This specification is intended as a guide only. Whilst the information it contains is believed to be correct. KNET can take no responsibility for action taken based on the information contained in this document. KNET reserved the right to make changes to this document without notice. All sales of product are subject to KNET's terms and conditions of sales only.
 Any unauthorized copying of this document or our products is prohibited and KNET will take action to prevent any infringement of it rights and to claim damages for the loss that it suffers.